



This document is intended only as an overview of commissioning the TKS 80 and the SawStop AIM technology. Before using the TKS 80, please ensure you have read the corresponding operating instructions, paying particular attention to the safety warnings included.



## WARNING

### Risk of injury due to uncontrolled start-up of the table saw

- Always disconnect the mains plug from the socket before performing any work on the machine.

## The TKS 80 EBS table saw –

Tips for day-to-day tasks: Checking the conductivity of the workpiece material, SawStop AIM technology and bypass mode.



The **SawStop AIM technology integrated into the TKS 80** can prevent the most serious cutting injuries. The core component of SawStop AIM technology is a **cartridge** that uses a spring to drive an aluminium block into the saw blade, should it come into contact with a conductive material, including for example human skin, during operation. Other conductive materials include non-ferrous metals, wet or statically charged materials, metal-coated materials, metallic saw stops, etc.

### 1. Parts of the device

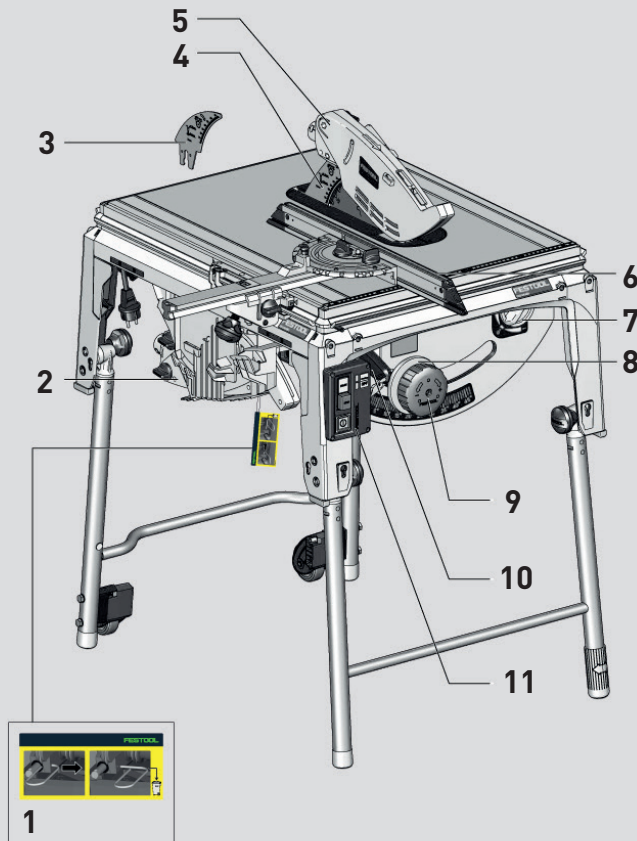

**[1] Shipping protection;** remove shipping protection [1] before commissioning for the first time.

**[2] Accessory holder**

**[3] Riving knife for grooving;** before commissioning for the first time remove the pre-fitted riving knife for grooving [3] and store this in the accessory holder [2].

**[4] Riving knife with guard support;** before commissioning for the first time, fit the riving knife with the guard (see operating instructions section 9.8).

**[5] Guard** (see operating instructions section 9.7).

**[6] Preset profile setting rail;** the preset profile setting rail can be set as a stopper and as a cross stop or angle stop.

**[7] Bevel angle fine adjustment**

**[8] Bevel angle setting**

**[9] Cutting height setting**

**[10] Push stick holder**

**[11] Switch panel**

### QuickGuides

Scan QR code to see videos demonstrating a range of functions.

Assembling the sliding table



Attaching the extension table for length expansion



Attaching the extension table for length expansion



Adjusting the preset profile setting rail



Angled cut



## 2. Commissioning

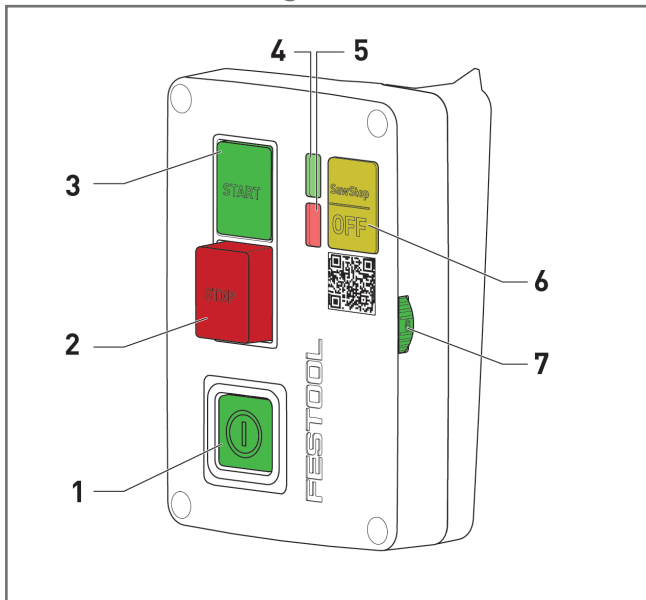

### Switching on

To switch on the machine, press the green main switch [1].

- The TKS 80 performs a self-check (green on, red flashing).
- Wait until the red LED goes out.
- The TKS 80 is then in standby mode.

Press the green START button [3].

- The TKS 80 is in sawing mode.
- The SawStop AIM technology is activated.

### Switching off

To switch off sawing mode, press the red STOP button [2]. Wait until the saw blade has come to a stop.



#### WARNING

The SawStop AIM technology only works with a protective earth connection and an earthed power source – Risk of injury

- › Make sure that power is not supplied via the SYS-PST 1500 or a transformer, for example.



#### WARNING

#### SawStop AIM technology is triggered

- › Do not touch the saw blade when it is coming to a stop. The SawStop AIM technology is still active and is triggered upon contact.

## 3. Checking conductivity

The conductivity of materials can be tested in advance to prevent accidental triggers.

1. Press the green main switch  
→ TKS 80 is ready for operation.
2. Hold the material against the saw blade:
  - › **Green** LED is **constantly lit**, **red** LED is **off**  
→ Material is **not** conductive.
  - › **Green** LED is **constantly lit**, **red** LED **flashes quickly**  
→ Material is **conductive**. Work in bypass mode.

Function monitoring



## 4. Bypass mode (deactivated SawStop AIM technology)

Only use bypass mode to saw conductive materials. When working in bypass mode, the SawStop AIM technology will not stop the saw blade upon contact with skin and so injuries can occur.

1. Press and hold the yellow SawStop AIM technology switch [6]. Red LED [5] flashes once, and after, without letting go, immediately press the green START button [3]. The TKS 80 starts up. The red LED [5] flashes again once.
2. Release the yellow SawStop AIM technology switch [6] and the green START button [3]. Green LED [4] flashes slowly, red LED [5] is off. The TKS 80 is ready for use in bypass mode.
3. Each time the saw is **started up again**, the SawStop AIM technology is **reactivated**. When working again with conductive materials, the bypass mode must be reactivated.

## 5. Changing the cartridge and saw blade

To change the saw blade and cartridge after the SawStop AIM function has been triggered, please refer to the operating instructions as well as the relevant QuickGuide:

Changing the saw blade    Changing the cartridge



#### WARNING

Noise generated when the SawStop AIM technology is triggered – Risk of accidents

- › Wear hearing protection.



#### WARNING

Risk of injury from ejected parts

- › The cartridge **AND** the saw blade must be replaced. Never use warped saw blades or saw blades with cracked or broken teeth.